



## Fenestration Requirements in Green Building Rating Systems: From the Perspective of Naturally Ventilated Buildings

Nina Lazar<sup>1\*</sup> and Soumya R<sup>2</sup>

<sup>1</sup> School of Architecture, Vellore Institute of Technology, Vellore, India.

<sup>2</sup> Sustainability Lead, ESG Wing, Kerala Infrastructure Investment Fund Board, Kerala, India.

\*Corresponding author: [nina.lazar@vit.ac.in](mailto:nina.lazar@vit.ac.in)

---

### **Article Info**

Submission date: 30th August 2024

Acceptance date: 20<sup>th</sup> December 2024

### **Keywords:**

green building rating systems; SHGC; solar heat gain coefficient; naturally ventilated buildings.

### **ABSTRACT**

Efforts in the building industry toward sustainable development are exemplified by green building rating systems. These systems establish sustainability criteria for certification, encompassing various aspects of construction. In India, Green Building Rating Systems (GBRS) mandate fenestration requirements, including aspects like overhang depth, Solar Heat Gain Coefficient (SHGC) of glazing, and minimum daylight area. When assessing cost considerations, many buildings opt for the SHGC parameter over overhang depth. For air-conditioned buildings, low SHGC values significantly curtail cooling loads and energy consumption. However, the benefit of reduced SHGC values is less pronounced in naturally ventilated buildings, where windows remain open for extended periods. This study employs building simulation to meticulously analyze the cost and advantages associated with implementing mandatory fenestration requirements in naturally ventilated buildings. The findings underscore that adopting low SHGC glazing in such buildings compromises daylight aspects with limited enhancement in thermal comfort, yet results in substantial cost escalation. Consequently, the study advocates for a relaxation of mandatory fenestration requirements in naturally ventilated buildings. Based on the above study the mandatory SHGC requirement was relaxed from 0.25 to 0.45.

---

## 1.0 INTRODUCTION

Green Building Rating Systems (GBRS) are globally acknowledged in the building sector as a pathway towards accomplishing Sustainable Development Goals (SDGs). GBRS was initially conceptualized in developed economies and focused on the environmental dimension, leaving behind sustainability's social and economic dimensions. Also, the initial GBRS was developed to suit air-conditioned buildings (Alapure Gopal Malba, 2017). Initially developed GBRS were subsequently adopted by developing economies (Alapure Gopal Malba, 2017). GBRS possesses a comprehensive structure that explores multiple domains of building design, construction, and operation and helps reduce energy consumption throughout the building lifecycle (Lazar & Chithra, 2018). GBRS also recommends the selection and design of fenestration parameters to reduce the solar heat gain through glazing and thereby reduce the cooling load and energy consumption (Lazar & Chithra, 2021a). In India, there exists several GBRS such as IGBC-Indian Green Building Council Rating System, GRIHA-Green Rating for Integrated Habitat Assessment, GEM-Green and Ecofriendly Movement, LEED-Leadership in Energy and Environmental Design, WELL standard, EDGE-Excellence in Design for Greater Efficiencies. GBRS that exists in India mandates fenestration parameters such as a minimum threshold for overhang depth, and a maximum threshold for Solar Heat Gain Coefficient (SHGC) of glazing, simultaneously mandating a minimum threshold for daylight area which could be achieved by varying the Window Wall Ratio (WWR) and Visual Light Transmittance (VLT) (Lazar & Chithra, 2021a). SHGC is the fraction of solar radiation admitted through glazing and a significant cause of indoor heat gain (ECBC, 2017). VLT describes the percentage of visible light transmitted through the glass and is the critical factor for the presence of daylight (ECBC, 2017). WWR is the percentage of Window/Openings in the façade in comparison to the entire façade area (ECBC, 2017). To maintain thermal comfort and daylight in indoor spaces, the SHGC and VLT need to be optimized (ECBC, 2017).

Most of the green building projects comply with the maximum SHGC threshold over the minimum overhang depth. In the case of air-conditioned buildings, low SHGC values significantly curtail cooling loads and energy consumption (Naji, 2020). The benefit of reduced SHGC values is less pronounced in naturally ventilated buildings, where windows remain open for occupied hours. Even though there are no significant benefits naturally ventilated green building projects also adhere to the maximum SHGC threshold to comply with the mandatory requirements of the GBRS and to attain green building certification. The design measures to comply with the mandatory requirements are causing a steep increase in costs with no significant benefits in the case of naturally ventilated buildings. Therefore, the current study aims to meticulously analyze the cost and advantages associated with implementing mandatory fenestration requirements in naturally ventilated buildings focusing Kerala region in India using building simulation as a tool. Kerala region falls into the warm humid climatic zone as per the Indian Climate Classification (BIS, 2005).

The paper is organized into multiple sections. The first section introduces the topic of research as well as the necessity of the research. The second section explains in detail the methods and materials adopted in the research with the help of a methodology flowchart. The third section describes the details of building modeling and alternative sample cases considered in the research. The fourth section presents the details of thermal comfort, daylighting, and cost analysis. The fifth section discusses the results. The sixth and seventh sections present the conclusion of the research and the implications of the research, respectively.

## 2.0 MATERIALS AND METHODS

The study progresses through multiple phases as shown in Figure 1, such as: 1) Critical review of mandatory fenestration requirements in GBRS; 2) Building modelling and defining alternative cases for simulation; 3) Building simulation and cost analysis.

### 2.1. Phase I: Critical Review fenestration requirements in GBRS

The first phase involves a comprehensive review of the GBRS to understand the various mandatory as well as voluntary fenestration requirements. This phase also identifies the various parameters that influence the performance of fenestration and helps in optimizing the thermal, visual, and energy performance of buildings.

### 2.2. Phase II: Building Modelling and Defining Alternative Cases for Simulation

This phase involves building modelling and determining alternative cases to be simulated to draw meaningful conclusions. Eight alternative cases are determined by changing the various fenestration parameters such as Window Wall Ratio (WWR), Type of glazing, and Window overhang.

### 2.3. Phase III: Analysis and Results

The third phase involves recording the building simulation results in terms of thermal, visual, and cost. To achieve the intent of the study, building simulation is conducted as follows: 1) Daylight analysis in terms of Daylight Factor (DF), Daylight Autonomy (DA), and Annual Sunlight Exposure (ASE); 2) Thermal comfort analysis; 3) Cost analysis, of eight alternative cases.

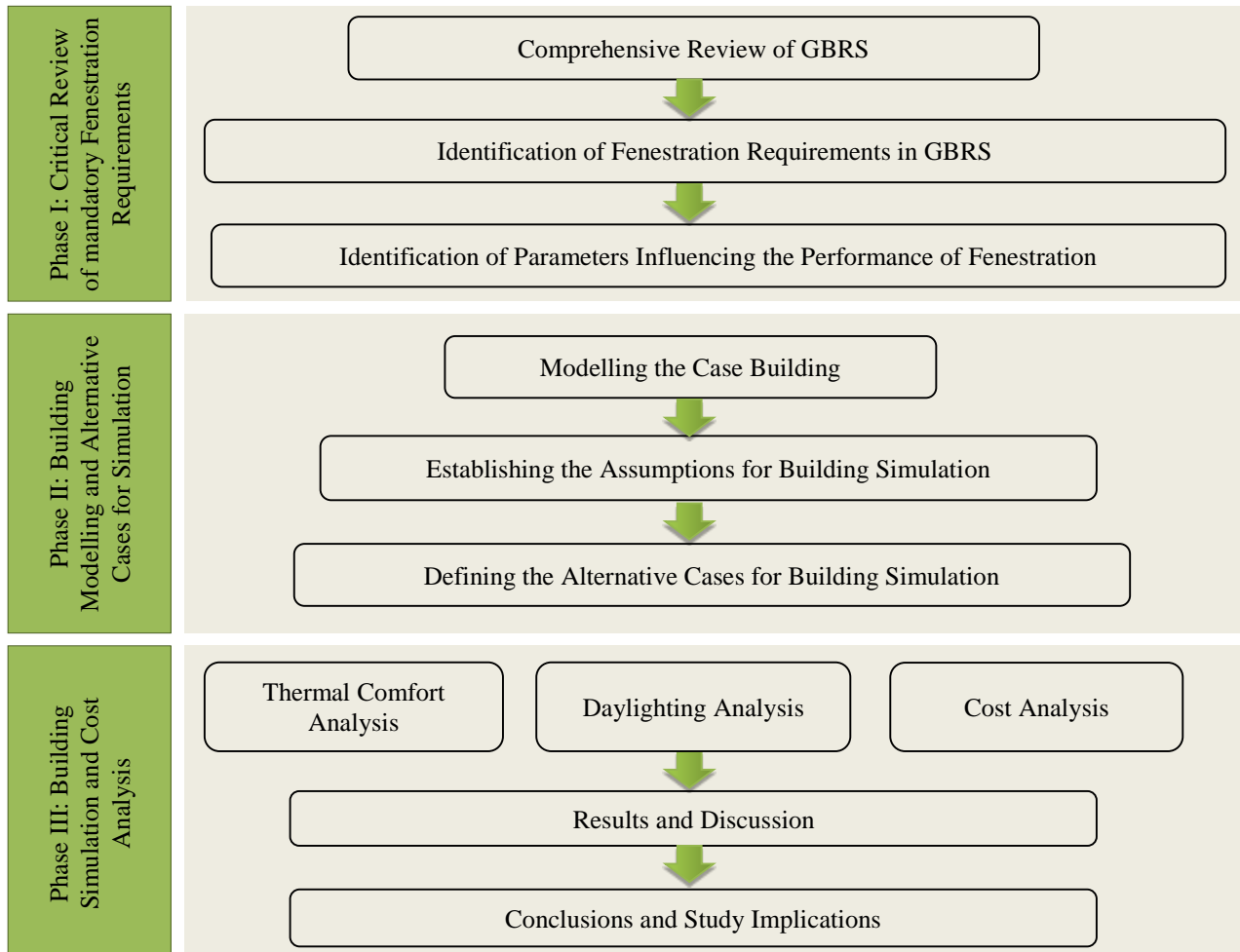

**Figure 1.** Methodology Flowchart

### 3.0 CRITICAL REVIEW OF MANDATORY FENESTRATION REQUIREMENTS

A comprehensive review of the GBRS that exist in India (BEE, 2007; GRIHA Council/TERI, 2016; IGBC, 2016; Lazar & Chithra, 2021b, 2022) revealed several options to comply with the mandatory fenestration requirements: 1) All the fenestrations meet the SHGC requirement of Energy Conservation Building Code (ECBC)-2007 of India/Weighted Façade average SHGC (for each orientation) meets SHGC requirements of ECBC-2007, India; 2) Use Tables 9 and 10 of SP 41 that exist in India to design the shading device for the windows; 3) Conduct solar path analysis for windows of air-conditioned as well as non-air conditioned spaces, to ensure that the window is completely shaded for the duration between 10:00 am on 1st April to 15:00 on 30th September.

As per option 1, the maximum allowable SHGC of glazing for the warm humid climatic zone as per ECBC is 0.25 and as per the Indian Green Building Council's (IGBC's) new building rating system is 0.45. Even though ECBC 2007 incorporated the SHGC requirements as a prescriptive requirement, GBRS mandates SHGC requirements as one among the three options. In the case of naturally ventilated buildings, where the windows are kept open most of the time, it is noted that low SHGC values don't make much increment in the thermal performance of the buildings; however, they increase the cost. Many international GBRS don't mandate/recommend SHGC requirements; instead, they focus on the Overall Thermal Transfer Value (OTTV)

(Malaysia Green Building Council (MGBC), 2013; Philippine Green Building Council (PGBC), 2018; Vietnam Green Building Council (VGBC), 2017) or Residential Envelope Transmittance Value (RETV) (BEE, 2018) to provide more flexibility for the architects while developing the building designs. For instance, the Green Building Index (GBI) (Malaysia Green Building Council (MGBC), 2013) in Malaysia and Building for Ecologically Responsible Design Excellence (BERDE) (Philippine Green Building Council (PGBC), 2018) in the Philippines shows compliance of thermal comfort through OTTV and ECBC for Residential Buildings (Eco-Niwas Samhita) in the Indian context launched by the Bureau of Energy Efficiency (BEE) adopts RETV (BEE, 2018). The OTTV and RETV provide a considerable opportunity to play with the envelope design regarding WWR, wall construction, building orientation, etc., to provide the most efficient building envelope with minimal cost. Naturally ventilated buildings can also ensure personal comfort requirements with adaptive comfort strategies to mitigate localized discomfort. Adopting such strategies provides a symbiotic balance between implementing design decisions from the designer's side (Rajasekar et al., 2014) and making an adaptive choice from the occupant side, such as user-controlled blinds, curtains, fans, clothing, etc.

As per option 2, the shading devices of windows are to be designed using Table 9 and Table 10 of SP 41, the handbook on functional requirements of buildings. Referring to Table 10 of SP 41 for the southern region (Kisan & Sangathan, 1987), which recommends the spacing distances between vertical or horizontal members of louver systems, it is found that the overhang required in the East/West orientation is approximately 5.5m and in the North/South direction is 0.55m. The recommendations in SP 41 and the corresponding calculations are shown in Table 1 and Table 2, respectively.

**Table 1.** Spacing distances between vertical/horizontals of louver systems as per SP41

(SOUTHERN REGION)										
(Clause 3.4.3)										
DIRECTION	TYPE OF LOUVER	SPACING BETWEEN VERTICAL OR HORIZONTAL ANGLE OF INCLINATION					DIRECTION OF INCLINATION	PERFORMANCE	RECOMMENDED	
		$B = 0^\circ$	$B = 15^\circ$	$B = 30^\circ$	$B = 45^\circ$	$B = 60^\circ$				
A North	Case 1	V	2.75 P	Inclining	not desirable		—	Cuts-off sun after 7 am during June and completely in other months	For non-air-conditioned buildings	
	Case 2	V	2.15 P	—	—	—	—	Cuts-off completely at all times	For air-conditioned buildings	
B South	Case 1	H	2.75 P	3 P	3.33 P	3.75 P	4.5 P	Downwards	Cuts-off all summer sun after 15 March to 30 September	Type H( $B = 0$ )
C East/West	Case 1	V	Inclining up to $30^\circ$ not desirable		0.53 P	1.27 P		Inclined towards north way from the normal	Cuts-off both summer and winter sun	—
	Case 2	H	0.27 P	0.54 P	0.85 P	1.27 P	2 P	Downwards	Cuts-off only after 7 am in summer and winter	Type C
	Case 3	C vertical member	Inclining up to $15^\circ$ not desirable		0.31 P	0.73 P	1.46 P	Inclined towards south away from normal	Completely cuts-off only summer sun but allows winter sun to come partially	Combination of types V( $B = 30^\circ$ ) and H( $B = 0^\circ$ )

(Continued)

**Table 2.** Overhang requirements as per SP 41

Direction	Type of Louver	Spacing for $0^\circ$ Angle of Inclination (x P)	Assumed window height (in m) (y)	Projection (P) required for single louver design (in m) ( $P = y/x$ )
South/North	Horizontal	2.75P	1.5	0.55
East/West	Horizontal	0.27P	1.5	5.5

Even though SP 41 recommends providing overhangs/fins, GBRS in India mandates the same. Since the Kerala state falls under the warm-humid climatic zone experiencing heavy monsoon rainfall, a minimum projection of 0.6 is desirable to adapt to the climatic conditions. However, the 5.5 m projection required in the East/West orientation adds to the cost and the structural load.

Considering option 3, the solar path analysis for windows of air-conditioned as well as non-air-conditioned spaces, is to be conducted to ensure that the window is completely shaded for the duration between 10:00 am on 1st April to 15:00 on 30th September. This is a tedious job, and the consultant/designer needs to invest many person-hours in coming up with the optimized shading design through several iterations. Therefore, this option seems to be impractical with respect to the amount of time and resources required to accomplish the task. Thus, the designer is forced to adopt the recommendations in SP 41 for shading design as such. Hence the third option also ends up increasing the cost as well as the structural load.

Considering the above, a study was conducted to analyze the cost and benefits of implementing the mandatory fenestration requirements in the GBRS in terms of SHGC and depth of overhangs, focusing on naturally ventilated buildings in Kerala, India. Therefore, the study aims to find the influence of mandatory fenestration requirements on project cost, thermal comfort, and daylighting of naturally ventilated buildings. The performance of fenestration is discussed in terms of depth of Overhang/Fins, SHGC, and VLT.

#### 4.0 BUILDING MODELLING AND DEFINING ALTERNATIVE CASES FOR SIMULATION

The assumptions and considerations made while building the simulation model regarding Location, Building geometry, Orientation, Wall material, Glazing material, and the alternative cases considered for analysis are explained below.

##### 4.1. Location

The location considered for analysis is Thiruvananthapuram ( $8.5241^\circ$  N,  $76.9366^\circ$  E), which is located on the southwest coast of India, representing the warm-humid climate that extends to the entire state of Kerala. The weather data of Thiruvananthapuram from the Indian Society of Heating, Refrigerating, and Air Conditioning Engineers (ISHRAE) database were adopted for simulation studies. The mean maximum temperature is  $34^\circ\text{C}$ , and the mean minimum temperature is  $21^\circ\text{C}$ , as shown in

Figure 2. The humidity is high and rises to about 90% during the monsoon season, as shown in Figure 3. Throughout the year, the mean RH lies above 70%.

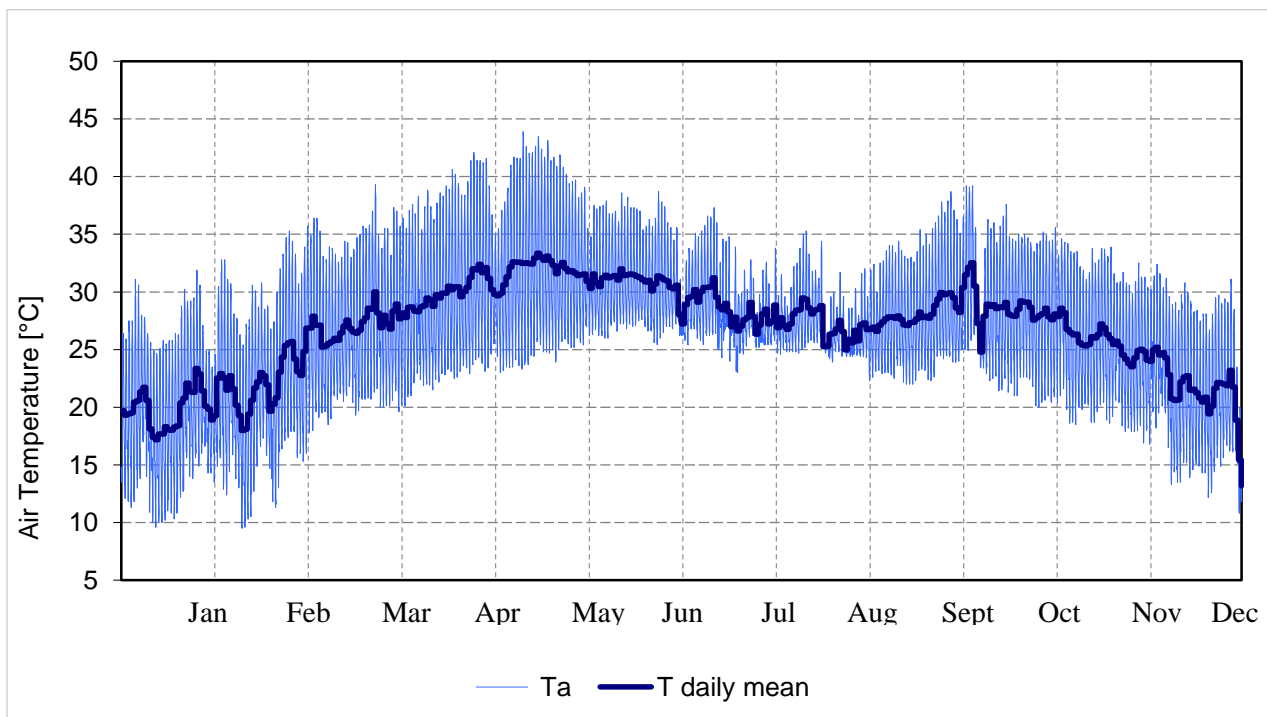

**Figure 2.** Hourly Ambient dry bulb temperature.

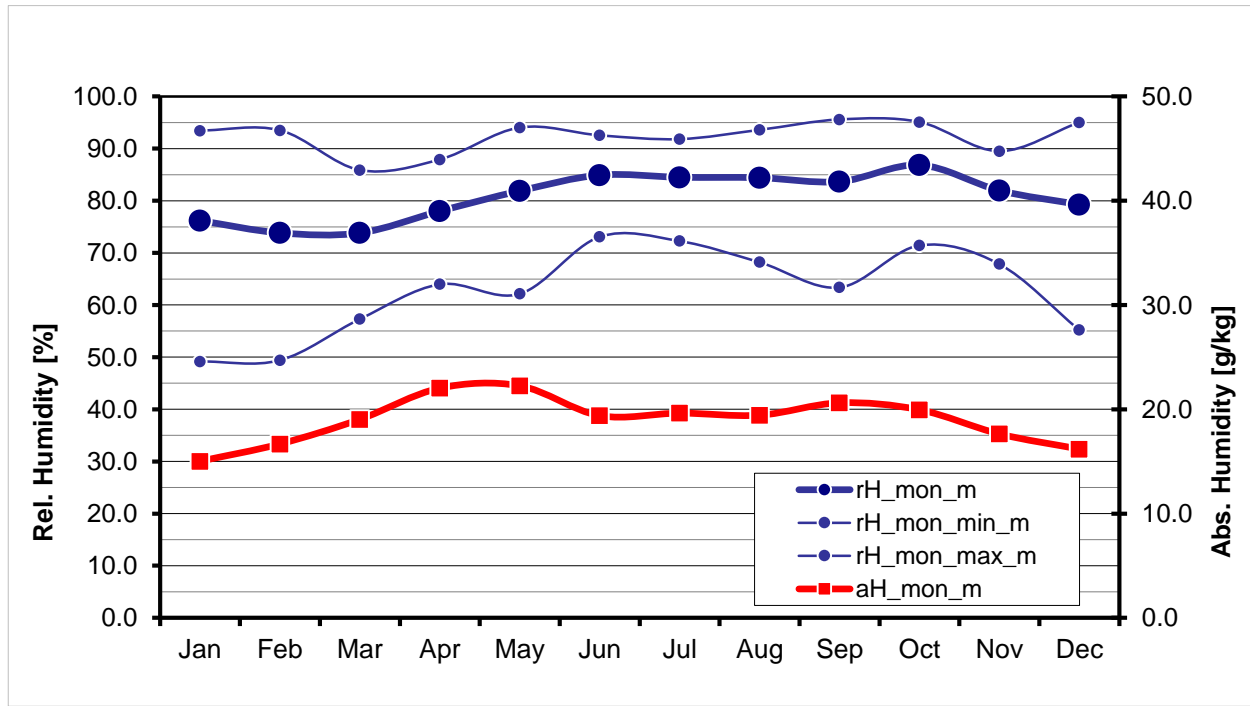

Figure 3. Humidity data

4.2. Building Geometry and Orientation

The building geometry considered for simulation is shown in Figure 4 for easy reference and understanding. The floor, roof, and north and east walls are considered adiabatic, as shown in Figure 4. The fenestration is orienting towards the South and West directions.

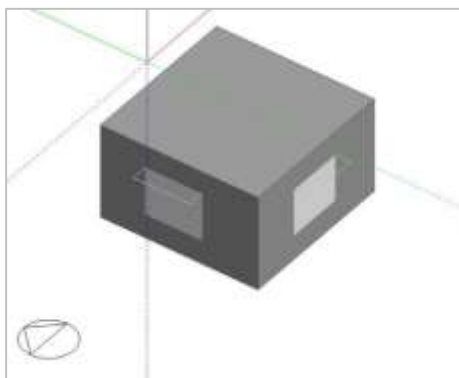

Figure 4 (a). Building geometry

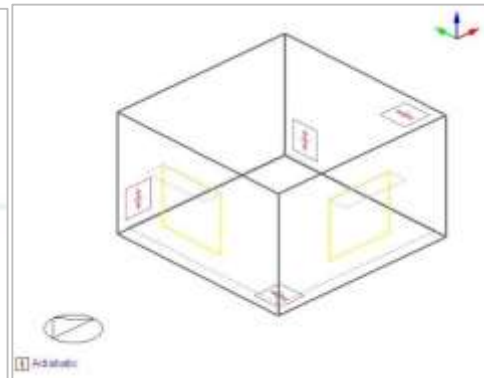

Figure 4 (b). Boundary conditions

4.3. Glazing Properties

Three types of glazing are considered for analysis as shown in Table 3 to Table 5. 1) SHGC – 0.25; 2) SHGC – 0.45; 3) SHGC – 0.86. The properties of the glazing are shown in Table 3, Table 4, and Table 5 respectively.

Table 3. Glazing Properties (SHGC – 0.25) Extracted from DesignBuilder

Definition method	
Definition method	2-Simple
Simple Definition	
Total solar transmission (SHGC)	0.250
Light transmission	0.270
<b>U-Value (W/m2-K)</b>	<b>3.300</b>

**Table 4.** Glazing Properties (SHGC – 0.45) Extracted from DesignBuilder

Definition method	
Definition method	2-Simple
Simple Definition	
Total solar transmission (SHGC)	0.450
Light transmission	0.308
<b>U-Value (W/m2-K)</b>	<b>5.067</b>

**Table 5.** Glazing Properties (SHGC – 0.86) Extracted from DesignBuilder

Definition method	
Definition method	2-Simple
Simple Definition	
Total solar transmission (SHGC)	0.860
Light transmission	0.890
<b>U-Value (W/m2-K)</b>	<b>5.800</b>

#### 4.4. Wall Properties

Autoclaved Aerated Concrete (AAC) masonry of 230mm thickness is considered for the wall. The properties of the wall considered are shown in Table 6.

**Table 6.** Wall Properties Extracted from DesignBuilder

Inner surface	
Convective heat transfer coefficient (W/m2-K)	2.152
Radiative heat transfer coefficient (W/m2-K)	5.540
Surface resistance (m2-K/W)	0.130
Outer surface	
Convective heat transfer coefficient (W/m2-K)	19.870
Radiative heat transfer coefficient (W/m2-K)	5.130
Surface resistance (m2-K/W)	0.040
No Bridging	
U-Value surface to surface (W/m2-K)	1.143
R-Value (m2-K/W)	1.045
<b>U-Value (W/m2-K)</b>	<b>0.957</b>
With Bridging (BS EN ISO 6946)	
Thickness (m)	0.2300
Km - Internal heat capacity (KJ/m2-K)	85.9260
Upper resistance limit (m2-K/W)	1.045
Lower resistance limit (m2-K/W)	1.045
U-Value surface to surface (W/m2-K)	1.143
R-Value (m2-K/W)	1.045
<b>U-Value (W/m2-K)</b>	<b>0.957</b>

#### 4.5. Alternative Cases Considered

The thermophysical properties of the material, the fenestration configurations used in the model, and the alternative cases considered are given in **Error! Reference source not found..** Most of the public building projects in Kerala are naturally ventilated buildings like colleges, schools, hospitals, offices, markets, etc. which attempt for green building certification, and the WWR ranges between 10% to 20%; hence two scenarios of WWR (10% and 20%) are considered. Three types of glazing



are considered for analysis, with SHGC 0.25, 0.45, and 0.86. An overhang of 5.5m is considered for windows in east/west orientation with SHGC 0.86 (As per SP41) and 0.6 m overhang for all other cases. Simulation studies involved modelling and analysis adopting the DesignBuilder Software trial version (v7.0.0.116).

**Table 7.** Details of alternative cases considered

Case	WWR	SHGC	VLT	U-Value	South Overhang	West Overhang	Remarks
Case A	20%	0.86	0.89	5.8	0.6 m	0.6 m	Base case in 20% WWR category
Case B	20%	0.86	0.89	5.8	0.6 m	5.5 m*	Case in compliance with option 2
Case C	20%	0.45	0.30	5.0	0.6 m	0.6 m	Case in compliance with SHGC 0.45
Case D	20%	0.25	0.27	3.3	0.6 m	0.6 m	Case in compliance with option 1
Case E	10%	0.86	0.89	5.8	0.6 m	0.6 m	Base case in 10% WWR category
Case F	10%	0.86	0.89	5.8	0.6 m	5.5 m*	Case in compliance with option 2
Case G	10%	0.45	0.30	5.0	0.6 m	0.6 m	Case in compliance with SHGC 0.45
Case H	10%	0.25	0.27	3.3	0.6 m	0.6 m	Case in compliance with option 1
Note:	* Overhang as per Table 10 of SP 41;						

**Case A:** Considered glazing with SHGC – 0.86, VLT – 0.89, and U value – 5.8 W/m<sup>2</sup>K, 0.6m overhang for windows in the south and west directions. Case A represents the case that doesn't comply with the mandatory fenestration requirements of GBRS. Case A is considered as a base case in this study. Case A has a WWR of 20%.

**Case B:** Considered glazing with SHGC – 0.86, VLT – 0.89, and U value – 5.8 W/m<sup>2</sup>K, 0.6m overhang for windows in the south direction, and 5.5m overhang in the west direction. Case B represents the case that complies with option 2 of mandatory fenestration requirements. Case B has a WWR of 20%.

**Case C:** Considered glazing with SHGC – 0.45, VLT – 0.30, U Value – 5.0 W/m<sup>2</sup>K, 0.6m overhang for windows in south and west directions. Case C represents the case that complies with the mandatory fenestration requirement of one of the GBRS. Case C has a WWR of 20%.

**Case D:** considered glazing with SHGC – 0.25, VLT – 0.27, and U Value – 3.3 W/m<sup>2</sup>K and 0.6m overhang for windows in the south and west directions. Case D represents the case that complies with option 1 of the mandatory fenestration requirements of GBRS. Case D has a WWR of 20%.

**Case E:** is the same as Case A except in the case of WWR. Case E has a WWR of 10%.

**Case F:** is the same as Case B except in the case of WWR. Case F has a WWR of 10%.

**Case G:** is the same as Case C except in the case of WWR. Case G has a WWR of 10%.

**Case H:** is the same as Case D except in the case of WWR. Case H has a WWR of 10%.

## 5.0 BUILDING SIMULATION AND COST ANALYSIS

Details of daylight simulation/analysis, thermal comfort simulation/analysis, and cost analysis corresponding to the alternative cases considered are presented in the following subsections.

### 5.1. Daylight Analysis

The daylight simulation with respect to Daylight Factor (DF), Daylight Autonomy (DA), and Annual Sunlight Exposure (ASE) was performed for eight alternative cases. The design sky illuminance is taken as 9000 lux, as the entire Kerala region comes under the warm-humid climatic zone. The daylighting simulation



is done on a work plane of 750 mm in height from the finish floor level.

**Daylight Factor (DF):** With reference to one of the mandatory fenestration requirements 25% of the living area should meet an adequate level of DF as prescribed in SP 41. DF is a metric used in architecture to measure the amount of daylight available inside a building in comparison to the amount of daylight available outside. Since the majority of the projects that attempt green building certification in Kerala are public projects and mainly include hospitals, institutions, markets, etc., the DF percent/threshold considered for the analysis is 1.25 (general wards of hospitals) ie. 112.5 lux. The analysis is done using the software DesignBuilder. The results of daylight analysis in terms of DF are shown in **Table 8** and Figure 5.

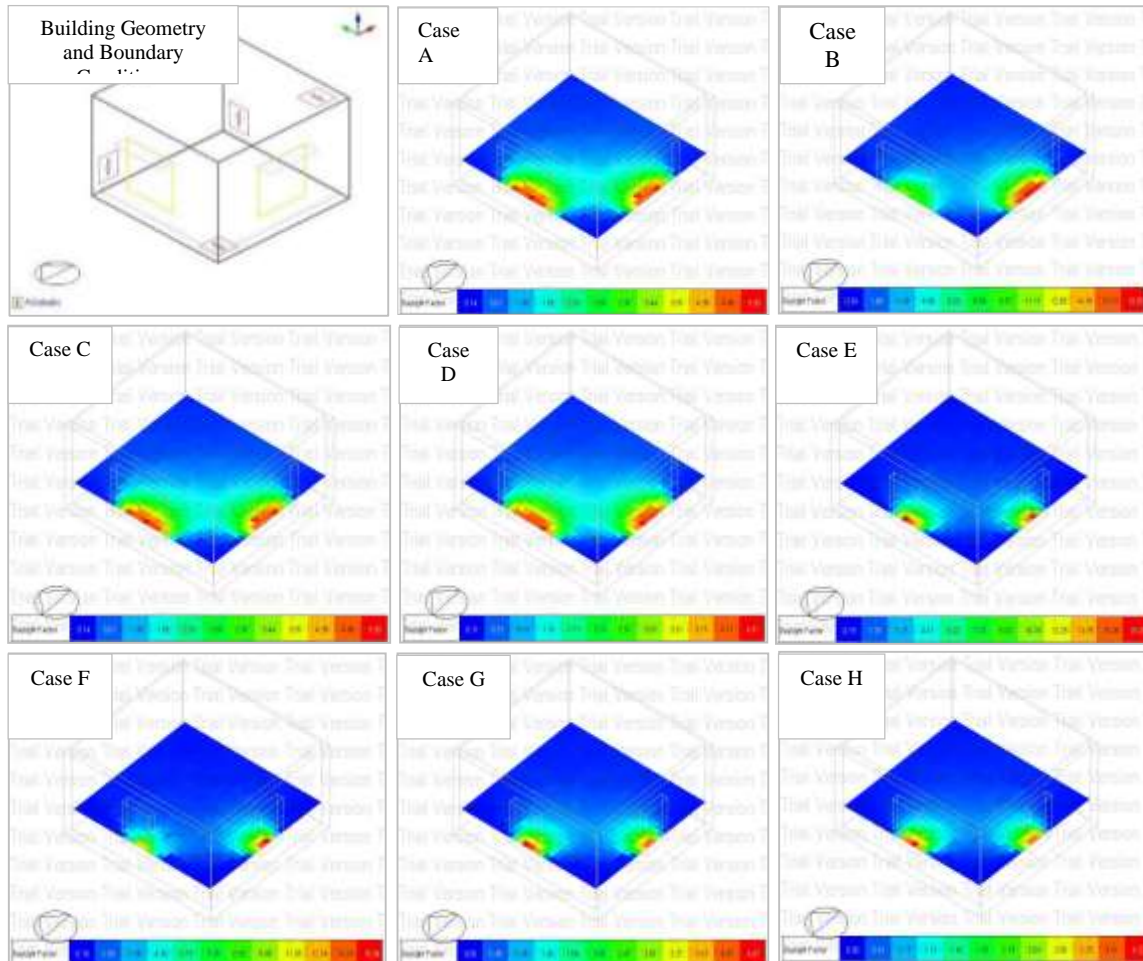

**Figure 5.** Results of Daylight Analysis

**Table 8.** Results of Daylight Analysis (DF)

Case	Floor Area (m <sup>2</sup> )	Floor Area within Limits (m <sup>2</sup> )	Floor Area within Limits (%)	Average Daylight Factor (%)	Average Illuminance (lux)
Case A	23.87	21.06	88.21	4.24	381.6
Case B	23.87	18.56	77.76	3.21	288.9
Case C	23.87	8.41	35.23	1.29	116.1
Case D	23.87	7.03	29.45	1.12	100.8
Case E	23.87	9.99	41.87	1.95	175.5
Case F	23.87	8.53	35.75	1.62	145.8
Case G	23.87	2.31	9.70	0.59	53.1
Case H	23.87	2.11	8.85	0.52	46.8

The results indicate that the maximum area complying with the DF requirement is seen in Case A (SHGC 0.86) for 20% WWR and Case E for 10 % WWR; whereas Case D and Case H (SHGC 0.25) have the minimum area complying with the DF requirement. Considering the DF requirement to show daylight availability for living areas, SHGC 0.86 and VLT 0.89 perform better than other cases in the respective WWR categories.

**Daylight Autonomy (DA):** With reference to the fenestration requirements of GBRS, it is mandatory that mean DA (300 lux or more) are met over the total living area for at least 25% of total analysis hours (area-weighted). To show compliance with DA, the simulation is done in terms of Spatial Daylight Autonomy (sDA). sDA is a measure of daylight illuminance sufficiency for a given area, reporting a percentage of floor area that exceeds a specified illuminance (e.g., 300 lux) for a specified amount of annual hours. The results of daylight analysis in terms of sDA are shown in Table 9.

**Table 9.** Results of Daylight Analysis (sDA)

Case	Floor Area (m <sup>2</sup> )	sDA Area in Range (m <sup>2</sup> )	sDA Area in Range (%)
Case A	23.87	23.87	100.0
Case B	23.87	23.71	99.32
Case C	23.87	18.97	79.48
Case D	23.87	16.85	70.58
Case E	23.87	21.89	91.70
Case F	23.87	20.83	87.27
Case G	23.87	7.62	32.18
Case H	23.87	5.98	25.03

The results indicate that the maximum area in range with respect to sDA is seen in Case A (SHGC 0.86) for 20% WWR and Case E for 10 % WWR; whereas Case D and Case H with (SHGC 0.25) have the minimum area complying to the sDA requirement. Considering the sDA requirement for living areas, glass with SHGC of 0.86 and VLT of 0.89 performs better than other cases in the respective WWR categories. It is also noted that case A is the only one that complies with the mandatory sDA requirement specified in GBRS. Moreover, it is too stringent to meet the mandatory sDA requirement for all other cases with low SHGC.

**Annual Sunlight Exposure (ASE):** As part of daylight analysis to understand the exposure to unwanted sunlight or glare, simulations were done to evaluate the Annual Sunlight Exposure ASE shows the number of hours where the lighting exceeds the threshold of 2000 lux (as recommended by ECBC) for each analysis grid. The analysis is done using the software DesignBuilder. The results of daylight analysis in terms of ASE are shown in Table 10 and Figure 6.

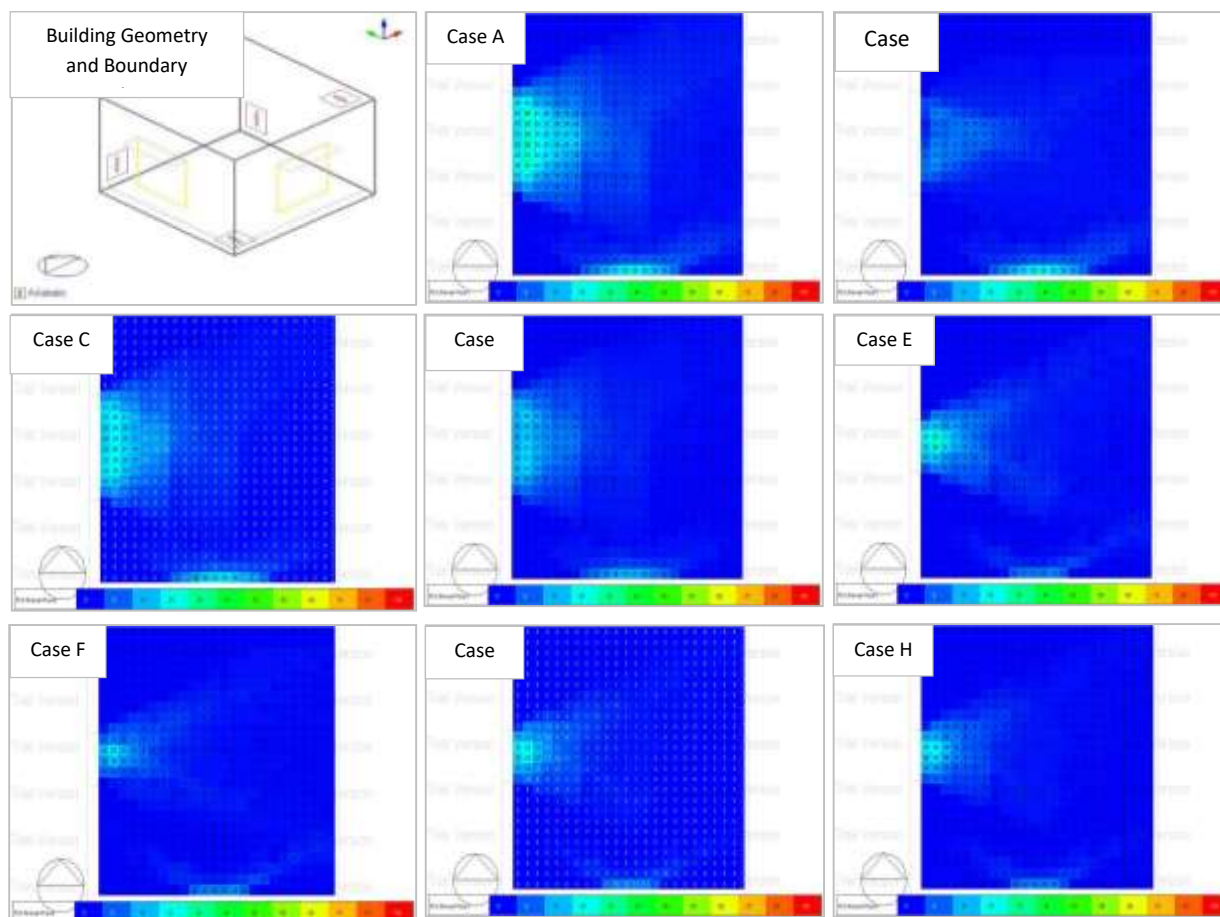

Figure 6. Results of Annual Sunlight Exposure (ASE) Analysis

Table 10. Results of Annual Sunlight Exposure (ASE) Analysis.

Case	Floor Area (m2)	ASE Area in Range (m2)	ASE Area in Range (%)	Area with Glare (%)
Case A	23.87	18.22	76.33	23.67
Case B	23.87	21.553	90.294	9.706
Case C	23.87	19.968	83.653	16.347
Case D	23.87	20.252	84.845	15.155
Case E	23.87	21.634	90.634	9.366
Case F	23.87	22.569	94.551	5.449
Case G	23.87	22.122	92.678	7.322
Case H	23.87	22.244	93.189	6.811

The results indicate that the maximum area in range with respect to ASE is seen in Case B (where the overhang is 0.6m and 5.5m in the south and west directions respectively) for 20% WWR and Case F for 10 % WWR; whereas Case D and Case H with (SHGC 0.25) shows only an 8% improvement when compared to CASE A (SHGC 0.86). It is noted that the percentage of glare showed a drastic improvement (14%) when the overhang depth is increased than lowering the SHGC. It is also evident that reducing WWR from 20% to 10% results in a significant reduction of glare component (14%). Hence, it is noted that the overhang depth and WWR have a significant influence on optimizing the glare component in buildings.

### 5.2. Thermal Comfort Analysis

With reference to the requirement in GBRS (GRIHA Council/TERI, 2016), the thermal comfort analysis of the cases mentioned in **Error! Reference source not found.** was performed according to the National Building Code (NBC) 2005, India for naturally ventilated buildings. The thermal comfort simulations were carried out in hourly time-steps. To comply with the criteria the thermal comfort requirements as per NBC

2005 shall be met for 60% of all the occupied hours for buildings in the warm and humid climate, in case of hourly calculations.

Table 11 shows the Temperature – Relative Humidity (RH) - Indoor air velocity combinations for comfort conditions specified in NBC.

**Table 11.** Desirable Wind Speeds (m/s) for thermal Comfort Conditions as per NBC

DBT	RH						
	30	40	50	60	70	80	90
	Wind speed (m/s)						
28	*	*	*	*	*	*	*
29	*	*	*	*	*	0.06	0.19
30	*	*	*	0.06	0.24	0.53	0.85
31	*	0.06	0.24	0.53	1.04	1.47	2.10
32	0.20	0.46	0.94	1.59	2.26	3.04	+
33	0.77	1.36	2.12	3.00	+	+	+
34	1.85	2.72	+	+	+	+	+
35	3.2	+	+	+	+	+	+

NBC 2005 specifies the minimum wind speed that should be maintained for a specific indoor temperature and relative humidity for achieving thermal comfort inside living spaces. The wind speed requirement could be achieved by natural/mechanical/by a combination of both. The highlighted cells in Table 12 show the combination of RH and temperature for which the indoor conditions are comfortable for an indoor air velocity of 1.5 m/s. In this study, an indoor air velocity of 1.5 m/s is maintained in summer using ceiling fans.

**Table 12.** Combination of Temperature and RH for Thermal Comfort Conditions as per NBC 2005.

DBT	RH						
	30	40	50	60	70	80	90
	Wind speed (m/s)						
28	*	*	*	*	*	*	*
29	*	*	*	*	*	0.06	0.19
30	*	*	*	0.06	0.24	0.53	0.85
31	*	0.06	0.24	0.53	1.04	1.47	2.10
32	0.20	0.46	0.94	1.59	2.26	3.04	+
33	0.77	1.36	2.12	3.00	+	+	+
34	1.85	2.72	+	+	+	+	+
35	3.2	+	+	+	+	+	+

The results of the thermal comfort analysis and the corresponding percentage of thermal comfort hours for all eight alternatives are presented in Table 13.

**Table 13.** Percentage of comfort hours

Case	Annual Analysis Hours	Total Comfort Hours	Thermal Comfort Analysis
Case A	8760	7283	83.14%
Case B	8760	7319	83.18%
Case C	8760	7319	83.55%
Case D	8760	7347	83.87%
Case E	8760	7434	84.86%
Case F	8760	7399	84.46%
Case G	8760	7440	84.93%
Case H	8760	7454	85.09%

The results indicate that all the cases achieve thermal comfort for more than 80% of the annual analysis hours. Hence it is evident that Case D and Case H with SHGC 0.25 are not showing any significant improvement in thermal comfort conditions with respect to other cases in the naturally ventilated scenario.

### 5.3. Cost Analysis

The cost for glazing with SHGC 0.25, 0.45, 0.86, and overhang 0.6m, 5.5m as per SP 41 is calculated and is shown in Table 14. Further, the cost details for the eight cases are computed.

**Table 14.** Cost Details of Glazing and Shading.

Cost for Glazing (Indicative)			Cost Details for Shading (Indicative) for 1m length					Remarks
Case	Cost in Rs/-	Per m of window	Depth of overhang	Cost for concrete	Cost for reinforcem xU	Total Cost		
<b>0.25 SHGC; 0.27 VLT</b>	2500 Rs	3750.00	Q	X= QxRXS	Y=QxRxT xU	Z=X +Y	Thickness (R) =7.5 cm; Concrete cost/cum (S) =9500; Reinf. cost/kg (T) =75; 128kg/cum of reinfo. (U)	
<b>0.45 SHGC; 0.30 VLT</b>	1200 Rs	1800.00	0.6m	428.00	432.00	860		
<b>0.86 SHGC; 0.89 VLT</b>	870 Rs	1305.00	5.5m	3920.00	3960.00	7880		
<b>Note*:</b> The window height is assumed as 1.5m								

## 6.0 FINDINGS AND DISCUSSION

The comparison of results regarding thermal comfort analysis, daylight analysis, and cost requirements for the eight alternative cases considered is shown in Table 15.

**Table 15.** Comparison of Results

Case	WWR	SHGC	VLT	U-Value	South Overhang	West Overhang	Daylight Analysis DF <sub>1.25</sub>	Area with Glare (%)	Thermal Comfort Analysis	Additional Cost per meter of window	% Increment for overall fenestration
Case A	20%	0.86	0.89	5.8	0.6m	0.6 m	88.21	23.67	83.14%	00.00	-
Case B	20%	0.86	0.89	5.8	0.6m	5.5m*	77.76	9.71	83.18%	7020.00	232.07%
Case C	20%	0.45	0.30	5.0	0.6m	0.6m	35.23	16.35	83.55%	495.00	16.36%
Case D	20%	0.25	0.27	3.3	0.6m	0.6m	29.45	15.16	83.87%	2445.00	80.82%
Case E	10%	0.86	0.89	5.8	0.6m	0.6m	41.87	9.37	84.86%	00.00	-
Case F	10%	0.86	0.89	5.08	0.6m	5.5m*	35.75	5.45	84.46%	7020.00	232.07%
Case G	10%	0.45	0.30	5.0	0.6m	0.6m	9.70	7.32	84.93%	495.00	16.36%
Case H	10%	0.25	0.27	3.3	0.6m	0.6m	8.85	6.81	85.09%	2445.00	80.82%

Note: The percentage increase is calculated considering Case A as the baseline.

The daylight analysis results indicate that the maximum area complying with the DF requirement is seen in Case A (SHGC 0.86) for 20% WWR and Case E for 10 % WWR, whereas Case D and Case H (SHGC 0.25) have the minimum area complying to the DF requirement. Considering the DF requirement to show daylight availability for living areas, SHGC 0.86 and VLT 0.89 perform better than other cases in the respective WWR categories, also the cases with increased overhang (Case B and Case F) show better performance with respect to reduction in glare. The thermal comfort analysis results indicate that all the cases achieve thermal comfort for more than 80% of the annual analysis hours. Hence it is evident that Case D and Case H with SHGC 0.25 are not showing any significant improvement in thermal comfort conditions with respect to other cases in the naturally ventilated scenario. The cost analysis results show that case A with SHGC 0.86 is the most cost-

effective option, which is kept as the base case. Case B shows the maximum cost increase (232.07%), with an overhang of 5.5 m in the west orientation to comply with the SP 41 shading requirement. With an SHGC of 0.45, Case C shows a cost increase of 16.36%. Case D also shows a cost increase of 80.82%, which has the lowest SHGC of 0.25; however, the cost rise in glazing alone is almost triple (from Rs. 1305/- to Rs. 3750/-).

Considering all the eight alternative cases, it is evident that Case A (SHGC 0.86 and 0.6m overhang) is the cost-effective option without compromising on visual and thermal comfort. Although case B (SHGC 0.86 and 5.5m west overhang) satisfies the daylight and thermal comfort requirement, it is the most expensive option. Case C (SHGC 0.45 and 0.6m overhang) satisfies the daylight and thermal requirements and incurs additional costs. Case D satisfies the daylight and thermal comfort requirement, and the enormous cost is incurred, approximately triple the cost of glazing.

Hence, the analysis and results indicate that relying solely on the Solar Heat Gain Coefficient (SHGC) has limitations when evaluating fenestration performance in naturally ventilated buildings. A more comprehensive approach would be to adopt a metric that integrates all envelope parameters, rather than considering SHGC as a standalone parameter for assessing sustainability. As discussed in Section 3, naturally ventilated buildings can ensure personal comfort requirements through adaptive comfort strategies that allow occupants to adjust their environment to suit their individual comfort needs. The adaptive comfort strategies include operable windows, user-controlled shading devices, and installing curtains and blinds, fans, and clothing. Adopting such strategies and choices helps in mitigating localized discomfort to a larger extent.

## 7.0 CONCLUSION

The current study critically analyses the mandatory fenestration requirements in GBRS and performs a study based on building simulation focusing on building projects in Kerala. Most of the projects in Kerala are constrained by orientation and land issues; hence most of the buildings are in less than favourable orientations. The use of high-performance glazing systems with low SHGC as mandated in GBRS compromises the daylight aspects compared to the clear glass without much improvement in thermal comfort in naturally ventilated buildings. Therefore, most of the projects are forced to use expensive double-glazed systems in most projects to meet the SHGC and daylight requirements simultaneously. The study results indicate that such a compulsion out of necessity affects the affordability aspects of the construction without many benefits, especially since all these windows will be kept open in practice in naturally ventilated buildings due to humidity and ventilation considerations.

### Implication Of The Study

Based on the current research the mandatory SHGC requirements were relaxed by one of the GBRS in India, from 0.25 to 0.45 for naturally ventilated spaces of warm-humid climatic zones, considering the additional cost without significant benefits. The study was able to review the mandatory fenestration requirements and was able to enhance and improve the quality of requirements comprehensively and critically. Affordability and utility are cardinal requirements for any green building, and it is expected that GBRS aims at affordable solutions.

## 8.0 ACKNOWLEDGEMENT

The authors are extremely thankful to the Kerala Infrastructure Investment Fund Board for the technical support rendered in carrying out the study, especially Mr. Ajit S, General Manager, Environmental Social and Governance Wing. The authors are also grateful to the SEED funding provided by VIT Vellore and also for the financial support provided by VIT Vellore for presenting the research in ICIUP 2024 held at Kuala Lumpur.

## 9.0 REFERENCES

- Alapure Gopal Malba. (2017). Sustainability Assessment Model for Buildings. Indian Institute of Technology Kharagpur.
- BEE. (2007). Energy Conservation Building Code 2007.
- BEE. (2018). Eco-Niwas Samhita. In Ministry of Power, Government of India (Vol. 1).
- BIS. (2005). National Building Code of India 2005.

- ECBC. (2017). Energy Conservation Building Code , 2017 Users ' Manual.
- GRIHA Council/TERI. (2016). GRIHA Version 2015. <http://grihaindia.org/>
- IGBC. (2016). IGBC Green New Buildings Rating System Version 3.
- Kisan, M., & Sangathan, S. (1987). SP 41 (1987): Handbook on Functional Requirements of Buildings (Other than Industrial Buildings) [CED 12: Functional Requirements in Buildings].
- Lazar, N., & Chithra, K. (2018). Green Building Rating Systems from the perspective of three pillars of Sustainability through Building Lifecycle.
- Lazar, N., & Chithra, K. (2021a). Evaluation of sustainability criteria for residential buildings of tropical climate: The stakeholder perspective. *Energy and Buildings*, 232, 110654. <https://doi.org/10.1016/j.enbuild.2020.110654>
- Lazar, N., & Chithra, K. (2021b). Prioritization of sustainability dimensions and categories for residential buildings of tropical climate: A multi-criteria decision-making approach. *Journal of Building Engineering*, 39, 102262. <https://doi.org/10.1016/j.job.2021.102262>
- Lazar, N., & Chithra, K. (2022). Benchmarking critical criteria for assessing sustainability of residential buildings in tropical climate. *Journal of Building Engineering*, 45(October 2021), 103467. <https://doi.org/10.1016/j.job.2021.103467>
- Malaysia Green Building Council (MGBC). (2013). GBI Assessment Criteria for Residential New Construction (RNC) Version 3.0.
- Naji, S. (2020). Multi-objective optimisation of a prefabricated house in Australian climate zones. <http://hdl.handle.net/11343/252715>
- Philippine Green Building Council (PGBC). (2018). BERDE GBRS - New Construction Version 2.2.0.
- Rajasekar, E., Anupama, U., & Venkateswaran, R. (2014). Thermal comfort beyond building design - an investigation in naturally ventilated residential apartments in a hot-dry climate. *Advances in Building Energy Research*, 8(2), 196–215. <https://doi.org/10.1080/17512549.2013.865553>
- Vietnam Green Building Council (VGBC). (2017). LOTUS Homes V1 Technical Manual.